



TT31 Mode S Transponder Installation Manual



00455-00-AJ

1 February 2010

Trig Avionics Limited
Heriot Watt Research Park
Riccarton, Currie
EH14 4AP
Scotland, UK

Copyright Trig Avionics Limited, 2009, 2010

This page intentionally left blank

CONTENTS

1. PREFACE	1
1.1 PURPOSE	1
1.2 SCOPE	1
1.3 CHANGES FROM PREVIOUS ISSUE	1
1.4 DOCUMENT CROSS-REFERENCES	1
2. INTRODUCTION	2
2.1 TT31 DESCRIPTION	2
2.2 INTERFACES	2
3. TECHNICAL SPECIFICATIONS	4
3.1 REGULATORY	4
3.2 PHYSICAL SPECIFICATIONS (IN TRAY)	4
3.3 INSTALLATION APPROVAL	4
4. UNIT AND ACCESSORIES SUPPLIED	5
4.1 TT31 MODE S TRANSPONDER ITEMS	5
4.2 INSTALLATION KIT	5
4.3 DOCUMENTATION KIT	5
4.4 REQUIRED ITEMS	5
5. INSTALLATION	7
5.1 UNPACKING AND INSPECTING EQUIPMENT	7
5.2 MOUNTING	7
5.3 COOLING REQUIREMENTS	7
5.4 ELECTRICAL CONNECTIONS	7
5.4.1 Primary Interface – Pinout	8
5.4.2 Secondary Interface - Pinout	9
5.4.3 Orientation Diagram	9
5.5 INTERFACE DETAILS	10
5.5.1 Power Input	10
5.5.2 Lighting Bus Input	10
5.5.3 Mutual Suppression	10
5.5.4 Altitude Inputs and Output	10
5.5.5 Ident Switch Input	11
5.5.6 Squat Switch Input	11
5.5.7 External Standby Input	11
5.5.8 Audio Output	11
5.5.9 Altitude Alerter Output	11

5.5.10	GPS Position Input	11
5.5.11	TIS Traffic Output.....	12
5.6	MOLEX CRIMP TERMINALS	12
5.7	ANTENNA INSTALLATION	12
5.7.1	Antenna Cable	13
5.7.2	BNC Connector.....	15
5.8	TRAY / BNC CONNECTOR ASSEMBLY	16
6.	INSTALLATION SETUP AND TEST.....	18
6.1	CONFIGURATION ITEMS.....	18
6.1.1	Aircraft Address Programming	18
6.1.2	VFR Squawk Code.....	18
6.1.3	VFR Flight ID.....	18
6.1.4	Airspeed Category.....	19
6.1.5	Aircraft Category.....	19
6.1.6	Squat Switch Source	19
6.1.7	TIS Output	19
6.1.8	GPS Input	19
6.1.9	GPS/TIS Line Speed	19
6.1.10	GPS System Integrity Level	19
6.1.11	Aircraft Length and Width.....	20
6.1.12	ADS-B Test Message Options.....	20
6.1.13	Audio Volume	20
6.1.14	LCD Dim Point.....	20
6.1.15	LCD Brightness	20
6.2	TEST ITEMS.....	21
6.2.1	Interface Check.....	21
6.2.2	Altitude Check.....	21
6.2.3	Lighting Bus.....	21
6.2.4	GPS Interface	21
7.	POST INSTALLATION CHECKS	22
8.	NORMAL OPERATION.....	23
8.1	OVERVIEW.....	23
8.2	DISPLAY	23
8.3	MODE SELECTOR KNOB	23
8.4	PUSH BUTTONS.....	24
8.5	CODE SELECTOR KNOB	24
8.6	FLIGHT TIMER	24

8.7	STOPWATCH	24
8.8	ADS-B POSITION MONITOR	24
8.9	ALTITUDE MONITOR	25
8.10	FAULT ANNUNCIATION.....	25
8.11	LOW TEMPERATURE OPERATION.....	25
9.	CONTINUED AIRWORTHINESS	26
10.	LIMITED WARRANTY	27
11.	ENVIRONMENTAL QUALIFICATION FORM.....	28
12.	ADS-B COMPLIANCE	30
12.1	ADS-B PARAMETERS SUPPORTED	30
12.2	ADS-B SERVICE LEVELS.....	30
12.3	AMC 20-24 COMPLIANCE	31
13.	INSTALLATION DRAWINGS	32
14.	BASIC INTERCONNECT DIAGRAM	33

This page intentionally left blank

1. Preface

1.1 Purpose

This manual describes the physical and electrical characteristics and the installation requirements for a TT31 Mode S Transponder.

1.2 Scope

This document applies to the installation of the TT31 Mode S Transponder.

At the publication date of this manual the software version identifier for the TT31 is 2.5 and the FPGA version identifier is 231006a. The software and FPGA versions are subject to change without notice.

1.3 Changes from Previous Issue

Change from Issue AI to Issue AJ comprises minor editorial changes, plus:

Section 2.2, Interfaces	Added reference to TIS traffic output.
Section 5.4.2, Secondary Output	Specified TIS traffic output pin.
Section 5.5.8, Audio Output	Clarification of output signals, addition of TIS audio.
Section 5.5.11, TIS Output	New section.
Section 6.1.2, VFR Code	Removal of German 0021 code.
Section 6.1.7, TIS Configuration	New section.
Section 6.1.12, ADS-B TEST Message	Changed to clarify preferred selection of TEST message behaviour.
Section 14, Wiring Diagram	Added optional TIS display.

1.4 Document Cross-References

00454-00	TT31 Mode S Transponder Operating Manual	AC
----------	--	----

2. Introduction

2.1 TT31 Description

The TT31 Mode S panel mount transponder is an ED-73B Class 1 compliant Mode S level 2es datalink transponder, with support for extended squitter, elementary surveillance and SI codes. The TT31 is also a DO-260A change 2 Class B0 compliant ADS-B out participant, which also meets the power output levels for Class B1. The TT31 meets the relevant environmental requirements of ED-14D, and is certified to ETSO 2C112b, ETSO C166a and TSO C112.

The TT31 transmitter power output is nominally 240 watts, and the transponder runs from either 14 volt nominal or 28 volt nominal DC power supply with no configuration changes required.

The TT31 transponder responds to both legacy Mode A/C interrogations and to Mode S interrogations from both ground radar and airborne collision avoidance systems. In all cases, the interrogations are received by the transponder on 1030MHz, and replies are transmitted on 1090MHz.

In the Mode S environment, S stands for Select, and a Mode S interrogator can selectively address a single transponder. This allows accurate position plotting with lower reply rates, which in turn reduces frequency congestion and interference. As a side benefit, power consumption by the transponder may be reduced, and simple datalink services can be supported, such as ADS-B. It is however crucial to the reliable operation of the system that each aircraft has a distinct Mode S address. The Mode S address is allocated by the registration authority for the aircraft, and must be set when the TT31 is installed.

2.2 Interfaces

At the rear, the transponder has two Molex style connectors and a single antenna connector for blind mating with the corresponding connectors in the mounting tray.

The interfaces provide the following services:

Parallel altitude input	Connection to an external altitude encoder using parallel Gray code.
Serial altitude input	Connection to an external RS232 altitude encoder. Using serial altitude data allows the transponder to report altitude with 25 foot resolution.
Serial altitude output	Connection to a GPS or other device needing serial altitude data – this allows the transponder to act as a repeater instead of requiring a second altitude encoder.
Ident input	External IDENT switch input.
Standby input	External standby input for dual transponder installations.
“On ground” input	Allows automatic flight/ground mode switching for aircraft with a squat switch.
Lighting bus input	Used to adjust the backlight and switch lighting intensity.
DME Suppression Input	Input to limit interference between DME interrogations and transponder replies – suppresses transponder whilst active.
Suppression bus I/O	ARINC compatible suppression bus signal used in aircraft with more sophisticated suppression needs, both an input to and output from the transponder.
Audio output	Optionally used by the altitude monitor function.
Audio mute input	Toggle function to mute the audio output.
Altitude alert output	Output used to signal altitude deviations when optional altitude monitor function is used.
GPS Input	Connection to a GPS supplying position input for ADS-B position reporting.

TIS Output RS232 output for connection to traffic display.

3. Technical Specifications

3.1 Regulatory

Specification	Characteristics
Compliance	ETSO 2C112b, TSO C112; Class 1 Level 2es ETSO C166a; Class B0
FCC Identification	VZI00220
Applicable documents	EuroCAE ED-73B, EuroCAE ED-14D (RTCA DO-160D), RTCA DO-181C, RTCA DO-260A
Software	ED-12B (RTCA DO-178B) Level B
Power Requirements	10 – 33 Volts DC. Typical 6.3Watts @ 14Volts.
Altitude	35,000 feet
Humidity	95% @ +50C for 6 hours; 85% @ +38C for 16 hours. Tested to Category A in DO-160D
Operating Temperature	-20C to +55C
Transmitter Frequency	1090MHz ± 1MHz
Transmitter Power	240 Watts nominal; 125 Watts minimum at antenna after allowing for 0.5dB connector losses and 1.5dB cable losses.
Transmitter Modulation	6M75 V1D
Receiver Frequency	1030 MHz
Receiver Sensitivity	-74dBm ± 3dB

3.2 Physical Specifications (in Tray)

Specification	Characteristics
Height	40mm (1.57")
Width	160mm (6.30")
Length	239mm (9.4")
Weight	2.8lbs. (1.35Kg)

3.3 Installation Approval

The conditions and tests required for the TSO approval of the TT31 Mode S Transponder are minimum performance standards. It is the responsibility of those desiring to install this transponder on or within a specific type or class of aircraft to determine that the aircraft operating conditions are within the TSO standards. The transponder may be installed only if further evaluation by the user/installer documents an acceptable installation that is approved by the appropriate airworthiness authority.

4. Unit and Accessories supplied

4.1 TT31 Mode S Transponder Items

Your TT31 Mode S transponder includes the following items:

Unit Description	Qty	Part Number
TT31 Mode S Transponder	1	00220-00
TT31 Mounting Tray	1	00231-00
TT31 Documentation Kit	1	00233-00
TT31 Installation Kit	1	00223-00

4.2 Installation Kit

Your TT31 installation kit includes the following items:

Unit Description	Qty	Part Number
12 way double sided crimp housing connector	1	00032-00
24 way double sided crimp housing connector	1	00033-00
Crimp Terminal, Female, 18-24 AWG	30	00236-00
Screw, Pozidrive, Pan Head M3x12mm lg	4	00422-00
Connector Co-axial Panel Mount Right Angle Blind Mate	1	00239-00
Circlip 7/16" External	1	00242-00
Washer 7/16" Plain, Stainless Steel	1	00241-00
Washer 7/16" Crinkle, Beryllium Copper	1	00317-00

4.3 Documentation Kit

Your TT31 documentation kit includes the following items:

Unit Description	Qty	Part Number
TT31 Transponder Installation Manual	1	00455-00
TT31 Pilots Operating Manual	1	00454-00

4.4 Required Items

Additional items you will require, but which are not in the TT31 package, include:

- Antenna and fixing hardware. The TT31 is compatible with any transponder antenna approved to ETSO C74 or 2C112.

- Altitude encoder. You require an encoding altimeter or a blind encoder with either parallel Gray code or RS232 serial output. For best results, and simpler installation, an encoder with a serial output is recommended.
- Cables. You need to supply and fabricate all required cables. Guidance on cable types is given in section 5 below.
- Fixings. To secure the transponder tray to the airframe you will need at least 6 flat head screws and six self-locking nuts. If the aircraft does not have existing mounting provisions you may need to fabricate additional brackets to support the transponder tray.

To support the optional ADS-B features a GPS receiver with an appropriate serial output is required.
To support the optional TIS features a display with an appropriate serial input is required.

5. Installation

5.1 Unpacking and Inspecting Equipment

Carefully unpack the transponder and make a visual inspection of the unit for evidence of any damage incurred during shipment. If the unit is damaged, notify the shipping company to file a claim for the damage. To justify your claim, save the original shipping container and all packaging materials.

5.2 Mounting

The TT31 Mode S transponder must be mounted rigidly in the aircraft panel. The following installation procedure should be followed, remembering to allow adequate space for installation of cables and connectors.

- Select a position in the panel that is not too close to any high external heat source. (The TT31 is not a significant heat source itself and does not need to be kept away from other devices for this reason).
- Avoid sharp bends and placing the cables too near to the aircraft control cables.
- Secure the mounting tray (p/n 00231-00) to the instrument panel via the six (6) mounting holes in the tray. It is important that the tray is supported at the rear two mounting holes as well as the front four.
- Check that the locking mechanism is correctly oriented by unscrewing the locking screw if required.
- Slide the TT31 transponder into the secured mounting tray.
- Lock the TT31 transponder into the mounting tray using a 3/32" Allen key, taking care not to over tighten the locking screw.

5.3 Cooling Requirements

The TT31 Mode S transponder meets all applicable ETSO requirements without forced air-cooling.

Attention should however be given to the incorporation of cooling provisions to limit the maximum operating temperature of each unit when the TT31 is installed in a typical panel or rack. The reliability of equipment operating in close proximity in a rack can be degraded if adequate cooling is not provided.

5.4 Electrical Connections

The TT31 has two Molex edge connectors, one with 24 contacts, which is the primary interface, and a second connector with 12 contacts which carries signals to support ADS-B and uplinked TIS traffic. A single coaxial connector attaches to the antenna. The only feature of the current TT31 that depends on the second Molex connector is the altitude alerter. In simple installations it is therefore possible to omit wiring for the second connector altogether.

The Molex edge connector used in the TT31 is similar to the connector used on the KT76A and KT78A transponders, and the common signals on the primary connector use the same contact positions and are electrically compatible. The antenna connector is also compatible. Providing that the wiring is appropriately installed, it is intended that you can upgrade a KT76A or KT78A installation to the TT31 without any connector rewiring. Before doing that however, you **MUST** check that the wiring for the existing transponder is in good condition.

5.4.1 Primary Interface – Pinout

Pin	Signal	Direction
1	Ground	-
2	Lighting 14V	Input
3	Lighting 28V	Input
4	Suppress I/O *	Bi-directional
5	Squat Switch In *	Input
6	Serial Alt Out *	Output
7	Serial Alt In *	Input
8	Altitude D4	Input
9	Suppress In	Input
10	Standby Switch	Input
11	11-33V DC	-
12	11-33V DC	-
A	Ground	-
B	Altitude B4	Input
C	Altitude B2	Input
D	Altitude C1	Input
E	Altitude B1	Input
F	Ident Switch In	Input
H	Altitude C4	Input
J	Altitude A4	Input
K	Altitude A2	Input
L	Altitude C2	Input
M	Altitude A1	Input
N	Do Not Connect *	-

*: These signals are different to the KT76A/KT78A pinout; on the KT76A and KT78A these signals are not usually connected in the aircraft.

The following diagram shows the connector orientation as it would be fitted to the mounting tray.

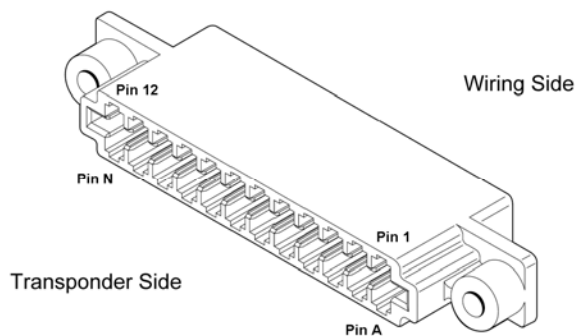

5.4.2 Secondary Interface - Pinout

Pin	Signal	Direction
1	Ground	-
2	TIS Traffic Out	Output
3	GPS Position In	Input
4	Reserved	Input
5	Audio Mute In	Input
6	Altitude Alert	Output
A	Ground	-
B	Audio +	Output
C	Audio -	Output
D	Reserved	-
E	Reserved	-
F	Reserved	-

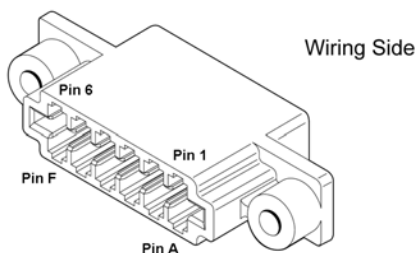

5.4.3 Orientation Diagram

To assist in connector orientation, the following example shows a typical set of connections. This diagram shows the expected connector positions when viewed from the transponder side of the tray, looking into the tray from the front. In the example shown the aircraft uses a 14 volt lighting bus, a parallel altitude encoder, a DME with simple suppression output, a GPS with serial position output, and a simple lamp for the altitude alerter. This example is representative of a simple fixed gear 14 volt aircraft.

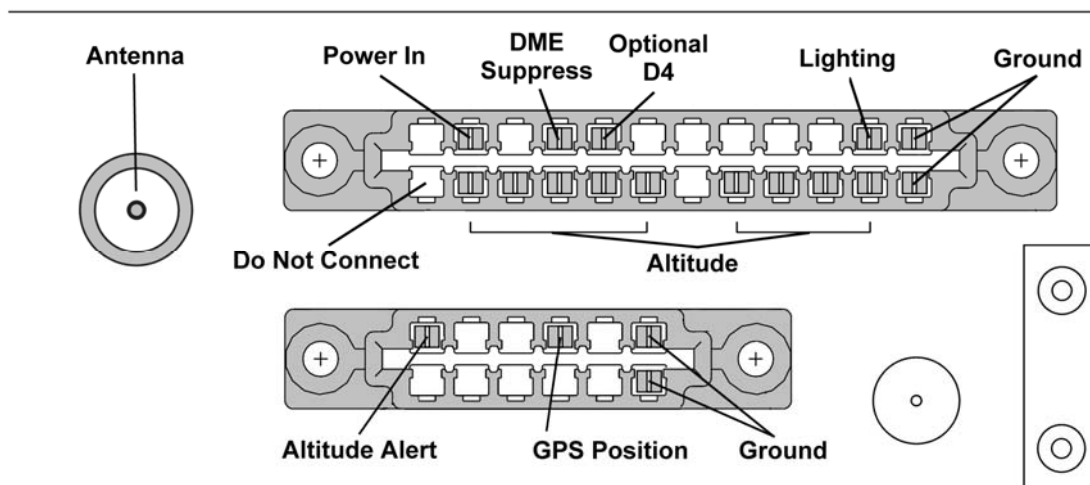

5.5 Interface Details

5.5.1 Power Input

The power supply can be 11-33 Volts DC; no voltage adjustment is required. Contacts 11 and 12 on the 24 way connector are both available as power inputs. This is for compatibility reasons only – internally the two are connected together, and in most installations only one need be connected to the power supply.

Use a 3 Amp circuit breaker for power supply protection to the TT31.

5.5.2 Lighting Bus Input

The TT31 will adjust the brightness of the front panel switch lighting according to the voltage on the lighting bus input. Two lighting bus inputs are provided on the 24 way connector to accommodate aircraft with 14 Volt or 28 Volt lighting systems. When the lighting bus operates at 28 Volts, connect the bus input to contact 3, and leave contact 2 unconnected. When the lighting bus operates at 14 Volts, connect the bus input to contact 2. In this case contact 3 can be left unconnected, but for backwards compatibility may also be grounded instead with no effect.

If no lighting bus input is detected, the TT31 will automatically control the front panel lighting based on the ambient light sensor.

5.5.3 Mutual Suppression

Mutual suppression allows two or more transmitters on adjacent frequencies to inhibit the other transmitters when one is active to limit the interference effects. It is commonly used between transponders and DME systems, and between transponders and collision avoidance systems.

The TT31 provides two styles of mutual suppression interface on the 24 way connector. The Suppress input on contact 9 is typically used in aircraft with simple DME systems and no other suppression requirements. It is an input only, and is active whenever the input is greater than approximately 5 Volts.

The Suppress I/O on contact 4 is an ARINC compatible suppression bus interface, which acts as both an input and an output. The TT31 will assert this signal when it is transmitting, and can be suppressed by other equipment that asserts the signal. The TT31 will drive approximately 24 Volts on the output (independently of supply voltage), and will treat the input as active whenever the bus has greater than 10 Volts.

5.5.4 Altitude Inputs and Output

The TT31 can use either a parallel Gray code altitude input, or serial RS232 altitude input. Both of these interfaces are on the 24 way connector. If the altitude encoder you are using offers both, we recommend using the RS232 serial input. Serial formats allow a higher resolution altitude representation that can be used by Mode S interrogations, whereas parallel Gray code format can only represent altitude to the nearest 100 feet. You must choose between serial or parallel formats – you should NOT connect both. If a parallel encoder is connected the TT31 will always use that as the altitude source even if a serial encoder is also connected.

The parallel encoder inputs are active when the voltage to ground is pulled below approximately 4 Volts. The TT31 includes internal isolation diodes which prevent the unit from pulling the encoder lines to ground when the transponder is switched off. The TT31 can therefore share the altitude inputs with other devices without needing external isolation.

Parallel output altitude encoders intended for operation below 30,000 feet may not have a signal connection for D4. In an aircraft with a service ceiling below 30,000 feet input D4 will never be active, and can safely be left unconnected.

The serial encoder input uses RS232 input levels. The communication should be 9600 bps, no parity.

The TT31 will correctly recognise either “Icarus/Trimble/Garmin” format altitude data, or “RMS” format altitude data. Refer to the encoder documentation to determine jumper settings as appropriate.

The TT31 includes a serial altitude output which repeats the altitude received on the encoded input (either parallel or serial) for connection to a GPS or other equipment. The serial output supplies RS232 output levels, and runs at 9600 bps, no parity. The output format is always “Icarus/Trimble/Garmin” format. If the altitude source is a parallel encoder, the serial output is reported every 0.5 seconds; if the source is a serial encoder, the output simply repeats the input reports, each report delayed by up to 10 milliseconds from the corresponding input report.

5.5.5 Ident Switch Input

The Ident switch input, on the 24 way connector, allows the IDENT function to be selected using a remote switch. The input is active low, and will be asserted when the voltage to ground is pulled below approximately 4 Volts.

5.5.6 Squat Switch Input

The Squat switch input allows the transponder to automatically switch between Airborne and Ground modes of operation. The squat switch will also automatically start and stop the flight timer. The input will be asserted when the voltage to ground is pulled below approximately 4 Volts. The operating mode of the squat switch can be programmed during setup to allow for active low or active high logical behaviour. For aircraft with no squat switch this input should be left open circuit, and the setup mode programmed for “Not Connected”.

5.5.7 External Standby Input

This input, when held low, places the transponder in Standby mode. It should be used to switch between transponders in an installation with two transponders. The input is active low, and will be asserted when the voltage to ground is pulled below approximately 4 Volts.

5.5.8 Audio Output

The Audio Output is on the 12 way secondary connector. The Audio Output is a balanced (two wire) audio output that can be connected to an unswitched input on the aircraft audio panel. Audio output is up to 10 Volts peak-to-peak across the pair when driving a 600 Ohm load; actual level can be adjusted at installation – see Section 6.

Note: The audio pair is not a true transformer balanced output – both pins are actively driven. If the audio panel input is single-ended, then only one of the output pins should be used, together with a local ground pin – the other audio output should be left floating.

The Audio Output carries the traffic alert messages for TIS, and the altitude audio annunciator used by the altitude monitor function.

5.5.9 Altitude Alerter Output

The TT31 includes an altitude monitor function that can alert the pilot to altitude deviations in cruise flight. The altitude alerter output, on the 12 way secondary connector, is switched to ground when the altitude deviation is detected and can be connected to a warning light or sounder to warn the pilot. The output is an open collector transistor, and can sink up to 1 Amp DC. The switched voltage should not exceed 60 Volts.

5.5.10 GPS Position Input

The GPS position input is required to support ADS-B functionality. The GPS position input is an RS232 input to the transponder and is on the 12 way secondary connector. The ADS-B features are optional – no GPS is required for normal Mode S Elementary Surveillance.

The TT31 GPS input can recognise the industry standard “Aviation” format, the NMEA 0183 format, or the format used by certain Freeflight and NexNav GPS sensors; the interface speed can be selected between 4800, 9600 and 19200 bps.

5.5.11 TIS Traffic Output

The TIS traffic output supports the display of uplinked Traffic Information Service messages. It is an RS232 output on the 12 way secondary connector. The TT31 TIS output can drive the Trig proprietary traffic protocol, and can also support the format used by certain Garmin handheld displays, including the 495, 496, 695 and 696.

Note: TIS is a Mode S uplink service that is provided by some US approach radars. TIS coverage is limited to the coverage areas of those radars. There is no TIS provision outside the USA.

5.6 Molex Crimp Terminals

The Molex connector contacts should be wired with wire of 18-24 AWG. The contacts are compatible with a wide range of crimp tools. Ensure that the contact has been crimped using both the conductor crimp and the insulator crimp.

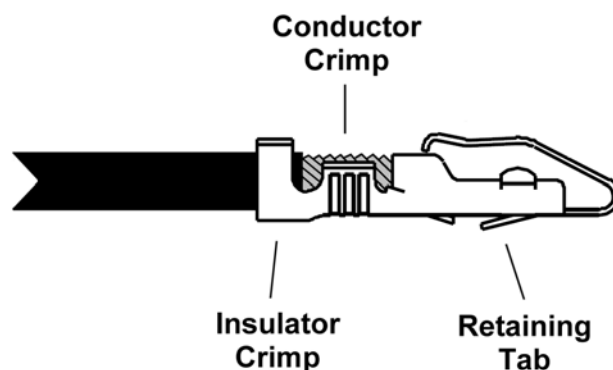

Once crimped, the contacts should be slotted into the rear of the connector shell. Push the contact in until the retaining tab clicks into place. Tug gently to confirm the contact is locked in place.

The contacts can be easily removed using the Molex removal tool, or equivalent. This is pushed gently into the connector shell from the side opposite from the wire entry, and lifts the retaining tab from the stop, allowing the contact to be eased out by pulling on the wire.

5.7 Antenna Installation

The antenna should be installed according to the manufacturer's instructions.

The following considerations should be taken into account when siting the Antenna.

- The antenna should be well removed from any projections, the engine(s) and propeller(s). It should also be well removed from landing gear doors, access doors or others openings which will break the ground plane for the antenna.
- The antenna should be mounted on the bottom surface of the aircraft and in a vertical position when the aircraft is in level flight.
- Avoid mounting the antenna within 3 feet of the ADF sense antenna or any COMM antenna and 6 feet from the transponder to the DME antenna.

- Where practical, plan the antenna location to keep the cable lengths as short as possible and avoid sharp bends in the cable to minimise the VSWR.
- To prevent RF interference, the antenna must be physically mounted a minimum distance of 3 feet from the TT31 Mode S transponder.

Electrical connection to the antenna should be protected to avoid loss of efficiency as a result of the presence of liquids or moisture. All antenna feeders shall be installed in such a way that a minimum of RF energy is radiated inside the aircraft.

5.7.1 Antenna Cable

The TT31 is designed to meet Class 1 requirements with an allowance of 2 dB for loss in the connectors and cable used to connect it to the antenna. Excessive loss will degrade both transmitter output power and receiver sensitivity.

Allowing 0.25dB loss for the connector at each end of the antenna cable assembly leaves an allowance of 1.5dB maximum loss for the cable itself.

An acceptable cable:

- Has less than 1.5dB loss for the run length needed
- Has a characteristic impedance of 50 Ohms
- Has double braid screens or has a foil and braid screen

Once the cable run length is known, a cable type with low enough loss per metre that meets the above requirements can be chosen. Longer runs require lower loss cable.

NOTE: Low loss cable typically uses foamed or cellular dielectrics and foil screens. These make such cables especially prone to damage from too-tight bends or from momentary kinking during installation. Once kinked, these cables do not return to full performance when straightened.

The following table is a guide to the maximum usable lengths of some common cable types. Actual cable loss varies between manufacturers, there are many variants, and the table is therefore based on typical data. Use it as a guide only and refer to the manufacturer's data sheet for your specific chosen cable for accurate values.

Max Length in Metres	Max Length in Feet	Insertion Loss dB/metre at 1090MHz	MIL-C-17 Cables	Electronic Cable Specialists Type
2.54	8' 4"	0.59	M17/128 (RG400)	
3.16	10' 4"	0.47		3C142B
3.81	12' 6"	0.39	M17/112 (RG304)	
5.25	17' 3"	0.29	M17/127 (RG393)	311601
6.42	21' 1"	0.23		311501
8.22	26' 11"	0.18		311201
12.59	41' 3"	0.12		310801

Contact Electronic Cable Specialists on +1 414 421 5300 or www.ecsdirect.com for their data sheets.

When routing the cable, ensure that you:

- Route the cable away from sources of heat.
- Route the cable away from potential interference sources such as ignition wiring, 400Hz generators, fluorescent lighting and electric motors.

- Allow a minimum separation of 300mm (12 inches) from an ADF antenna cable
- Keep the cable run as short as possible
- Avoid routing the cable round tight bends.
- Avoid kinking the cable even temporarily during installation.
- Secure the cable so that it cannot interfere with other systems

5.7.2 BNC Connector

This section describes the technique for attaching the antenna cable to the supplied blind-mate BNC connector.

If a low-loss cable is needed that has too large a dielectric diameter to fit the supplied blind-mate BNC connector, a short length (up to 150mm or 6 inches) of smaller cable may be used with suitable mating connectors to adapt to the transponder connector.

- Strip back the coax cable to the dimensions in the table, as shown in the diagram below. Slide 25 mm (1 inch) of heat shrink tubing over the cable.

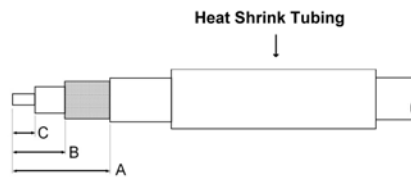

Dimension	Cut size (mm)	Cut size (inches)
A	12.7	0.5
B	6.4	0.25
C	3.2	0.125

- Insert the cable into the connector – the inner conductor should align with the centre contact, the inner shield should be inside the body of the connector and the outer shield should be outside the body.

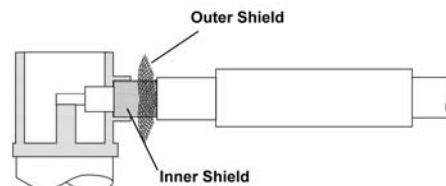

- Solder the centre conductor to the centre contact, aligning the conductor with the slot in the contact. Avoid excess solder heat on the centre BNC conductor pin.
- Solder the inner shield to the inside of the connector body by applying a soldering iron to the body and running solder into the gap. Try to avoid excess solder heat on the connector body.
- Solder the outer shield to the outside of the connector body. Avoid excess solder heat on the connector body.

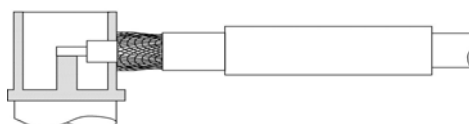

- Slide heat shrink tubing forward (flush to connector) and heat to shrink the tubing.



- Complete the assembly by installing the bushing over the centre contact, and fitting the cap. Solder the cap in place in at least two places.

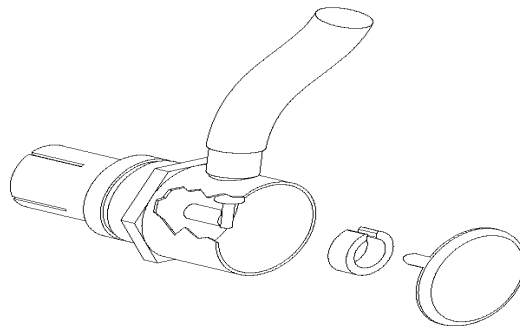

5.8 Tray / BNC Connector Assembly

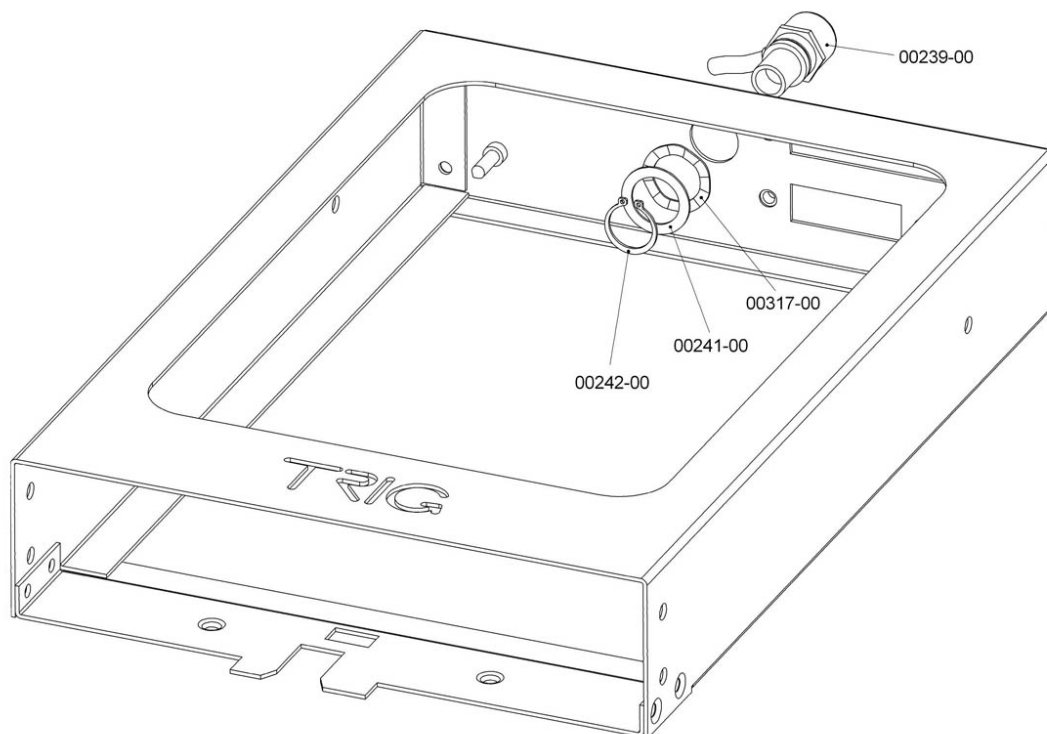

When the BNC is prepared, feed it through the TT31 mounting tray and attach the washer combination in the following order:

- Wave washer (p/n 00317-00).
- Plain washer (p/n 00241-00).
- Circlip washer (p/n 00242-00).

The Circlip washer should be fitted with a set of Circlip pliers.

The two Molex connectors should be passed through the openings in the rear of the tray, and then mounted firmly to the tray from the inside using the four M3 screws supplied.

6. Installation Setup and Test

The TT31 uses a simple setup system to program important system parameters, including the Mode S address. In the original factory configuration, the setup screen is the first thing that runs when you switch on the transponder. If the transponder has already been configured, and you want to access the setup screen again, simply hold down the FUNC button while switching on the transponder and the setup system will run.

The script will prompt for the following configuration items:

- Mode S Address
- VFR Squawk Code
- VFR Flight ID (Registration)
- Aircraft Maximum Airspeed
- Aircraft Category
- Squat switch source, if fitted
- GPS position source, if fitted, and ADS-B parameters
- TIS output format, if used
- Audio Output Volume
- LCD Dimming Settings

It will then run some simple installation diagnostics, including an external interface check, a check of the altitude encoder interface, and a check of the lighting bus input.

All the programming is accomplished using the right hand rotary knob and the ENT, BACK and FUNC buttons. Make all input selections using the rotary knob. Pressing the ENT button accepts the current input and advances to the next input item. Pressing the BACK button allows you to change something you have already entered. Pressing the FUNC button moves directly to the next screen.

6.1 Configuration Items

6.1.1 Aircraft Address Programming

The Mode S Address is a 24 bit number issued to the aircraft by the registration authority for the aircraft. These addresses are usually written as a 6 digit hexadecimal number, although you may also encounter one written as an 8 digit octal number. The TT31 only understands the hexadecimal format, so you must first convert an octal number to hexadecimal.

Enter the 6 digit aircraft address using the rotary knob and the ENT button.

6.1.2 VFR Squawk Code

When the pilot presses the VFR button, a pre-programmed code will replace the current squawk code. The code is set up next; the choice of code will depend on the normal location of the aircraft. In the USA, the VFR squawk code is 1200. In most parts of Europe, the VFR squawk code should be set to 7000.

Enter the 4 digit squawk code using the rotary knob and the ENT button.

6.1.3 VFR Flight ID

The default Flight ID for an aircraft not on an IFR flight plan should be the aircraft registration. Enter

the aircraft registration using the rotary knob and the ENT button.

Note that the aircraft registration is loaded as letters and numbers only. There are no dashes or other punctuation marks, and no spaces can be inserted. When you enter a space it finishes the data entry and moves to the next item.

6.1.4 Airspeed Category

Mode S transponders can transmit their maximum airspeed characteristics to aircraft equipped with TCAS. This information is used to help identify threats and to plan avoiding action by the TCAS equipped aircraft. The airspeeds are grouped in ranges; using the rotary knob, select the range that corresponds to the aircraft.

6.1.5 Aircraft Category

To assist ATC tracking of aircraft, an aircraft category can be transmitted by Mode S transponders. Using the rotary knob, select the aircraft category that most closely matches the aircraft the transponder is installed in.

6.1.6 Squat Switch Source

The Squat switch input allows the transponder to automatically switch between Airborne and Ground modes, and to automatically start and stop the flight timer. The sense of the squat switch input can be selected using the rotary knob. If the squat switch input is not connected the “Not Connected” option must be selected.

6.1.7 TIS Output

If the aircraft has a Traffic Information Service (TIS) compatible display connected to the transponder, select the appropriate interface protocol using the rotary knob.

Note: TIS is a Mode S uplink service that is provided by some US approach radars. TIS coverage is limited to the coverage areas of those radars; there is no TIS provision outside the USA.

6.1.8 GPS Input

If a GPS is connected for ADS-B position reporting, select the appropriate interface protocol using the rotary knob.

6.1.9 GPS/TIS Line Speed

If a GPS input or TIS output has been configured, you should select the appropriate line speed using the rotary knob. Traffic displays using the Garmin protocol run at 9600 bps. Panel mount GPS units with Aviation format outputs generally also run at 9600 bps. NMEA GPS units generally run at 4800 bps. Freeflight 1201 and NexNav 3101 GPS receivers generally run at 19200 bps.

Note: The TIS output and GPS input speeds are not separately controlled on the TT31. Not all combinations of GPS input and TIS output will be usable if the external devices operate on fixed bit rates and are different to each other.

6.1.10 GPS System Integrity Level

An important metric for ADS-B ground system behaviour is the SIL or System Integrity Level. It is intended to reflect the probability that the GPS position source is providing erroneous information. A detailed analysis of the contribution to system integrity is outside the scope of this manual, and the installer may need to carry out a system safety analysis to determine the best value to set. However, a reasonable guideline might be:

Equipment	Transmitted Integrity Level
VFR only GPS or uncertified installation	Low
GPS installation certified for en-route and terminal IFR navigation	Medium
GPS installation certified with augmentation, such as WAAS or LAAS	High

6.1.11 Aircraft Length and Width

On the ground, ADS-B transmits encoded aircraft size information which is used by ATC to identify taxiing routes and potential conflicts. When configured for ADS-B, the TT31 will ask for the aircraft length and width (wingspan), in metres, and will calculate the appropriate size code for transmission.

6.1.12 ADS-B Test Message Options

Because of limitations in the ATC radar computer systems, in some airspace an ADS-B equipped aircraft is required to periodically transmit the Mode A squawk code in an ADS-B squitter message. This allows the computer system to reconcile conventional radar traces with ADS-B information in a mixed surveillance environment. Because the Mode A code does not form part of the base ADS-B message set, the code is sent in a “TEST” message.

Because different regulatory authorities have not agreed on the behaviour of the TEST message, the installer must select the local preferred behaviour. For aircraft registered in the USA, or otherwise relying on the FAA TSO approval for the TT31, the TEST message should always be transmitted.

For other airworthiness approval authorities, the preferred behaviour is to apply a geographical filter so that these messages are only sent when the aircraft is visible to US radar systems. Because it has a GPS position input, the transponder already knows the geographic position of the aircraft, and therefore in this case, the recommended option setting for these messages is “Only in America”.

6.1.13 Audio Volume

The altitude alert function includes an audio alert. This configuration item lets you adjust the audio volume output from the transponder using the rotary knob. Whilst you are turning the volume control, the transponder will periodically output a test signal to verify the settings.

6.1.14 LCD Dim Point

The LCD backlight illumination is controlled automatically by the ambient light sensor. Depending on the amount of light spill in the cockpit, and the brightness of other adjacent avionics displays, it may be necessary to adjust the darkest setting of the backlight to best match other equipment and to improve the cockpit appearance.

Note – it is only practical to do this in pitch darkness, since that is the in-flight environment that you are trying to reproduce. If you are working in a hangar with any other lighting it may be better to leave the setting in the mid-range.

6.1.15 LCD Brightness

The actual maximum brightness of the LCD cannot be increased with this control. What it controls is the rate at which the lighting increases in brightness as the ambient light increases. This allows the brightness to be matched to other avionics displays during light level changes as far as possible.

6.2 Test items

6.2.1 Interface Check

The Interface Check screen displays the current state of the external IDENT, external STANDBY and external GROUND inputs. Exercise these inputs to confirm the correct behaviour.

6.2.2 Altitude Check

The Altitude check displays the current state of the altitude inputs. Individual Gray code lines are shown to assist in fault tracing.

6.2.3 Lighting Bus

The lighting bus check displays the voltage on the lighting bus to assist in verifying the correct operation of the lighting bus.

6.2.4 GPS Interface

The GPS interface check provides a simple confidence check that the transponder is receiving data on the RS232 input. Note that this check does not attempt to decode the received data; it is intended only to provide a quick wiring check in the hangar. To assure that the interface is fully operable the aircraft should be tested with the transponder in normal operating mode, with the GPS receiver operating correctly, and a ramp test of the transmitted parameters completed.

7. Post Installation Checks

Post installation checks should be carried out in accordance with your certification requirements. These checks should include:

- Mode S interrogations to verify correct address programming.
- Verification of the reported altitude using a static tester. For aircraft using parallel Gray code encoders, the test should include a range of altitudes up to 6,800 feet, 14,800 feet or 30,800 feet, depending on the service ceiling of the aircraft – these altitudes correspond to code changes which are not otherwise tested at lower altitudes.
- Where installed, verification of correct squat switch ground/airborne indications. In an aircraft with a squat switch, setting the Mode switch to ALT when the aircraft is on the ground should leave the transponder in GND mode; when the aircraft becomes airborne, the mode should switch automatically to ALT.
- Interrogations to verify the receiver sensitivity. A Mode S transponder should have a minimum triggering level (MTL) of between -77 dBm and -71 dBm. Failure to meet this requirement usually indicates antenna or coaxial cable problems.
- Interrogations to verify the transmitted power. A Class 1 installation should have no less than 125 Watts at the antenna (and no more than 500 Watts). Failure to meet this requirement is also generally due to antenna or wiring issues.
- Where installed, verification of the GPS position source and ADS-B outputs. In an aircraft with a configured GPS, pressing the FUNC button on the transponder front panel in normal operation will display the ADS position monitor. With the aircraft outside the hangar (for good GPS reception) the aircraft position should be displayed on the transponder. If the position indications are all dashes then either the GPS position is not valid or the GPS interface is not correctly configured. Whenever a valid position is received by the transponder and the transponder is in any mode other than Standby, ADS-B Extended Squitters should be observed on the transponder test set.
- Where installed, verification of the TIS output. A Mode S test set with TIS capability should be used; with the transponder in ALT mode traffic should be shown on the attached display.

8. Normal Operation

8.1 Overview

On the front panel is an amber backlit LCD display flanked by a rotary mode selector knob (OFF, SBY, GND, ON, and ALT) and a continuously rotating knob used for code and data entry.

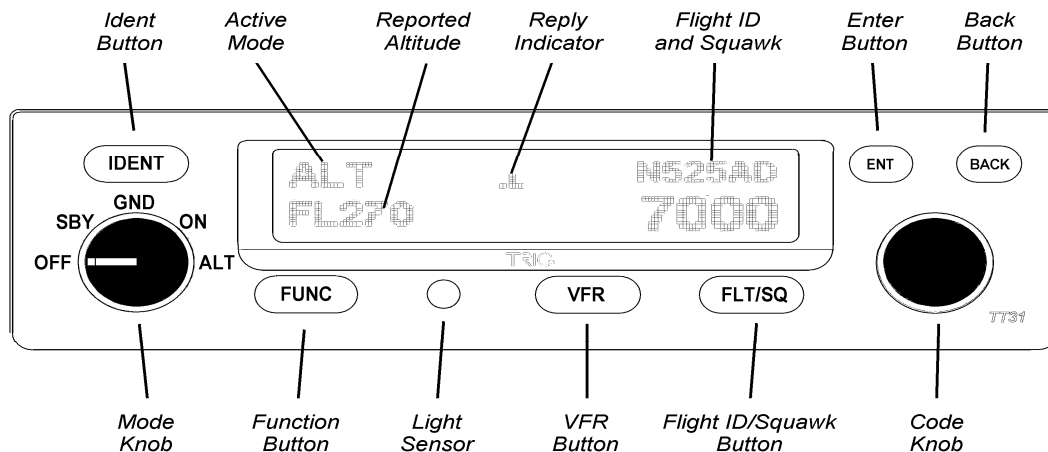

8.2 Display

The display shows the operating mode of the transponder, the reported pressure altitude, and the current squawk code and Flight ID. The reply indicator is active when the transponder replies to interrogations.

The pressure altitude is displayed as a Flight Level, which is the pressure altitude in hundreds of feet. When non-standard atmospheric conditions apply, this may not match the altimeter indicated altitude, but will be correctly displayed by the ATC radar.

8.3 Mode Selector Knob

The left hand knob controls the power to the transponder and the operating mode.

- OFF Power is removed from the transponder.
- SBY The transponder is on, but will not reply to any interrogations.
- GND The transponder will respond to Mode S ground interrogations from surface movement radar.
- ON The transponder will respond to all interrogations, but altitude reporting is suppressed.
- ALT The transponder will respond to all interrogations.

When airborne, the transponder should always be set to ALT unless otherwise directed by Air Traffic Control. When you are taxiing on the ground, the transponder should be set to GND unless your installation includes a gear squat switch. Aircraft installations that include a gear squat switch will automatically select GND on landing.

8.4 Push Buttons

- IDENT** Press the IDENT button when ATC instructs you to “Ident” or “Squawk Ident”. This activates the SPI pulse in the transponder replies for 18 seconds. IDENT will appear in the display.
- FUNC** Pressing the FUNC button provides access to the flight timer, stopwatch and altitude monitor function. When the aircraft is ADS-B equipped, pressing FUNC also provides access to the ADS-B position monitor.
- VFR** Pressing the VFR button sets the transponder to the pre-programmed conspicuity code. Pressing the button again restores the previous squawk code.
- FLT/SQ** Pressing FLT/SQ alternates the primary display between squawk code and Flight ID.
- ENT** The ENT button enters a digit in the code selector.
- BACK** The BACK button goes back to the previous digit in the code selector.

8.5 Code Selector Knob

The right hand knob is used to set squawk codes and the Flight ID. The FLT/SQ button selects which will be updated. Turning the knob will highlight the first digit on the display, and the digit can be changed as required. Press the ENT button to advance to the next digit. When ENT is pressed on the last digit, the new squawk code or Flight ID will replace the previous value. If the code entry is not completed within 7 seconds, the changes are ignored and the previous code restored.

1200	VFR code in the USA
7000	VFR code commonly used in Europe.
7500	Hijack code
7600	Loss of communications
7700	Emergency code

The Flight ID should correspond to the aircraft call sign entered on your flight plan. If no flight plan is active, the aircraft registration should be used as your Flight ID. Use only letters and digits. If the Flight ID is less than 8 characters long, entering a blank character will end it.

8.6 Flight Timer

The Flight Timer records the time for which the transponder has been powered on and operating in flight mode – either ON or ALT. Press the FUNC button to display the Flight Timer.

8.7 Stopwatch

The stopwatch can be used as a convenient timer. Press the FUNC button to display the stopwatch. Pressing ENT will reset and start the timer. Pressing ENT again will stop the timer.

8.8 ADS-B Position Monitor

The ADS-B position monitor is available on aircraft equipped for ADS-B position output. It provides a convenient way of verifying that valid position information is being received by the transponder by displaying the current calculated position. If a valid position is displayed, the transponder will be transmitting that position to ADS-B participants. If no position is available the position will be

displayed as dashes, and the transponder will NOT be transmitting ADS-B position information.

8.9 Altitude Monitor

The Altitude Monitor activates an audio annunciator or annunciator light (depending on installation) when the aircraft pressure altitude differs from the selected altitude by more than 200 feet. Press the FUNC button to display the altitude monitor enable screen. Pressing ENT toggles the altitude monitor at the current altitude.

When altitude monitoring is in use, a small deviation pointer appears adjacent to the altitude display on the transponder.

8.10 Fault Annunciation

If the transponder detects an internal failure, the screen will indicate FAULT and a brief statement of the problem. No replies will be made to interrogations when a fault is detected.

8.11 Low Temperature Operation

The TT31 is certified for correct operation at temperatures down to -20 Celsius. At low temperatures however the display performance will be impaired. The aircraft cockpit should be warmed to allow normal operation of the transponder before takeoff.

9. Continued Airworthiness

Other than for periodic functional checks required by the regulations, the TT31 Mode S transponder has been designed and manufactured to allow “on condition maintenance”. This means that there are no periodic service requirements necessary to maintain continued airworthiness, and no maintenance is required until the equipment does not properly perform its intended function. When service is required, a complete performance test should be accomplished following any repair action. Repairs should only be carried out in accordance with Trig Avionics Limited service procedures.

10. Limited Warranty

Trig Avionics Limited warrants our products to be free from defects in materials and workmanship for a period of two (2) years from the date of installation by an authorised dealer.

This warranty covers repair and/or replacement at our option, of any parts found to be defective, provided such defects in our opinion are due to faulty material or workmanship and are not caused by tampering, abuse, or normal wear.

All warranties are F.O.B.

Trig Avionics Limited
Heriot Watt Research Park
Riccarton, Currie, EH14 4AP

Trig Avionics will not accept or pay for any charges for warranty work performed outside our factory without prior written consent.

This warranty applies only to products in normal use. It does not apply to units or circuit boards defective due to improper installation, physical damage, tampering, lightning or other electrical discharge, units with altered serial numbers, or units repaired by unauthorised persons or in violation of Trig Avionics Limited service procedures.

Trig Avionics Limited assumes no responsibility for any consequential losses of any nature with respect to any products or services sold, rendered, or delivered.

11. Environmental Qualification Form

Nomenclature	TT31 Mode S Transponder		
Part Number:	00220-(XX)	ETSO:	2C112b
Manufacturer	Trig Avionics Limited		
Address	Heriot Watt Research Park, Riccarton, Currie, Scotland, EH14 4AP		
Conditions	DO-160D Section	Description of Conducted Tests	
Temperature and Altitude	4.0	Equipment tested to Categories A1, C1	
Low temperature ground survival	4.5.1	-55°C	
Low temperature operating	4.5.1	-20°C	
High temperature operating	4.5.3	+55°C	
High temperature short-time operating	4.5.2	+70°C	
High temperature ground survival	4.5.2	+85°C	
Loss of Cooling	4.5.4	Cooling air not required (+70°C operating without cooling air)	
Altitude	4.6.1	35,000 feet	
Decompression	4.6.2	8,000 to 35,000 feet in 15 seconds	
Overpressure	4.6.3	-15000 feet	
Temperature Variation	5.0	Equipment tested to Category C	
Humidity	6.0	Equipment tested to Category A	
Operational Shocks	7.2	Equipment tested to Category B	
Crash Safety	7.3	Equipment tested to Category B and extended to use test levels for Helicopters	
Vibration	8.0	Aircraft zone 2; type 3, 4, 5 to category S level M Equipment at strike-off level 3 also tested for aircraft zone 2; type 1 (Helicopters) to category U level G	
Explosion	9.0	Equipment identified as Category X – no test required	
Waterproofness	10.0	Equipment identified as Category X – no test required	
Fluids Susceptibility	11.0	Equipment identified as Category X – no test required	
Sand and Dust	12.0	Equipment identified as Category X – no test required	
Fungus	13.0	Equipment identified as Category X – no test required	
Salt Spray	14.0	Equipment identified as Category X – no test required	
Magnetic Effect	15.0	Equipment tested to Category Z	
Power Input	16.0	Equipment tested to Category B	
Voltage Spike	17.0	Equipment tested to Category B	
Audio frequency conducted susceptibility	18.0	Equipment tested to Category B	
Induced signal susceptibility	19.0	Equipment tested to Category A	
Radio frequency susceptibility	20.0	Equipment tested to Category T	
Radio frequency emission	21.0	Equipment tested to Category B	
Lightning induced transient susceptibility	22.0	Equipment identified as Category XXXX – no test required	
Lightning direct effects	23.0	Equipment identified as Category X – no test required	
Icing	24.0	Equipment identified as Category X – no test required	
Electrostatic Discharge	25.0	Equipment identified as Category X – no test required	

Because the ETSO for ADS-B was published later than the ETSO for transponders it refers to a later edition of the environmental standard, ED-14E/DO-160E, rather than ED-14D/DO-160D. The following form provides the environmental data in DO-160E format. The two tables are equivalent.

Nomenclature	TT31 Mode S Transponder		
Part Number:	00220-(XX)	ETSO:	C166a
Manufacturer	Trig Avionics Limited		
Address	Heriot Watt Research Park, Riccarton, Currie, Scotland, EH14 4AP		
Conditions	DO-160E	Description of Conducted Tests	
Temperature and Altitude	4.0	Equipment tested to Categories A4, C4	
Low temperature ground survival	4.5.1	-55°C	
Low temperature operating	4.5.1	-20°C	
High temperature operating	4.5.3	+55°C	
High temperature short-time operating	4.5.2	+70°C	
High temperature ground survival	4.5.2	+85°C	
Loss of Cooling	4.5.4	Cooling air not required (+70°C operating without cooling air)	
Altitude	4.6.1	35,000 feet	
Decompression	4.6.2	8,000 to 35,000 feet in 15 seconds	
Overpressure	4.6.3	-15000 feet	
Temperature Variation	5.0	Equipment tested to Category C	
Humidity	6.0	Equipment tested to Category A	
Operational Shocks	7.2	Equipment tested to Category B	
Crash Safety	7.3	Equipment tested to Category B and extended to use test levels for Helicopters	
Vibration	8.0	Aircraft zone 2; type 3, 4, 5 to category S level M Equipment at strike-off level 3 also tested for aircraft zone 2; type 1 (Helicopters) to category U level G	
Explosion	9.0	Equipment identified as Category X – no test required	
Waterproofness	10.0	Equipment identified as Category X – no test required	
Fluids Susceptibility	11.0	Equipment identified as Category X – no test required	
Sand and Dust	12.0	Equipment identified as Category X – no test required	
Fungus	13.0	Equipment identified as Category X – no test required	
Salt Spray	14.0	Equipment identified as Category X – no test required	
Magnetic Effect	15.0	Equipment tested to Category Z	
Power Input	16.0	Equipment tested to Category B	
Voltage Spike	17.0	Equipment tested to Category B	
Audio frequency conducted susceptibility	18.0	Equipment tested to Category B	
Induced signal susceptibility	19.0	Equipment tested to Category AC	
Radio frequency susceptibility	20.0	Equipment tested to Category T	
Radio frequency emission	21.0	Equipment tested to Category B	
Lightning induced transient susceptibility	22.0	Equipment identified as Category XXXX – no test required	
Lightning direct effects	23.0	Equipment identified as Category X – no test required	
Icing	24.0	Equipment identified as Category X – no test required	
Electrostatic Discharge	25.0	Equipment identified as Category X – no test required	
Fire, Flammability	26.0	Equipment identified as Category C	

12. ADS-B Compliance

TT31 transponders with software version 2.3 and above include support for Extended Squitter ADS-B out. The TT31 is a DO-260A change 2 compliant category B0 broadcast-only participant, which also meets the power output levels for category B1.

12.1 ADS-B Parameters Supported

The following table lists the ADS-B parameters that are transmitted by the TT31 transponder when connected to an appropriate GPS receiver.

Parameter	BDS Register	
SPI	0,5	
Emergency Indicator	0,5	
Barometric Altitude	0,5	
Quality Indicator (NIC)	0,5	
Airborne Position	Latitude	0,5
	Longitude	0,5
Quality Indicator (NIC)	0,6	
Surface Position	Latitude	0,6
	Longitude	0,6
Surface Ground Speed	0,6	
Surface Ground Track	0,6	
Aircraft Identification	0,8	
Airborne Ground Velocity	0,9	
Emergency Status	6,1	
Quality Indicator (NACp)	6,5	
Quality Indicator (SIL)	6,5	
Version Indicator	6,5	
Surface Length/Width	6,5	

In addition the TEST message with 4096 squawk code information can also be transmitted to support coordination with ATC radar systems. TEST message transmission status is an installation option.

12.2 ADS-B Service Levels

ADS-B forms part of the future plans for airspace management, and is being deployed in certain limited applications. The following summary of the ADS-B service is current at the date of publication of this manual, but you should be aware that regulatory changes are taking place in this area, and the most recent regulatory information should be consulted.

There are currently three levels of service that an ADS-B transmitter can provide.

Operational ADS-B Surveillance EASA has published the certification requirements for using ADS-B position information for Air Traffic Control services in a non-radar environment, AMC20-24. AMC20-24 includes both

technical attributes of the individual components of an installation and system attributes for the overall aircraft installation. AMC20-24 has been adopted as a base standard for ADS-B surveillance in other parts of the world, and provides radar-like separation capabilities between participating IFR aircraft.

Experimental ADS-B Surveillance

ADS-B trials have taken place in a number of countries which, because of the experimental nature, have allowed deviations from the operational standards represented by AMC20-24, but which have been based on positional information with comparable integrity.

ADS-B Information

There are a number of non-certified applications of ADS-B technology such as fleet monitoring and traffic awareness which can be deployed using position sources of lower integrity which, because the integrity is reported in the transmissions, are also compatible with the ADS-B surveillance environment.

There is also a widely publicised fourth level of service in discussion which is the US “Next Generation” plan, but at the time of publication of this manual a number of key aspects of this are undefined and no compliance statement against that future plan is practical.

The TT31 is designed to provide all of the required parameters listed in AMC20-24. However, in order to be used for separation services AMC20-24 sets additional criteria related to the position accuracy and integrity of the GPS position source used, and the ability for the GPS to communicate those accuracy and integrity parameters to the ADS-B output system in the transponder. At the publication date of this manual, the only commercially available GPS receivers we are aware of that can be used with the TT31 to meet the system requirements of AMC20-24 are the Freeflight 1201 and the NexNav 3101.

A wide range of other GPS receivers can be used as the position source for ADS-B, including ETSO-129a receivers and simpler VFR GPS receivers. Whilst these receivers may be suitable for Informational or Experimental installations, they generally lack one or more of the required integrity parameters for an operational IFR separation application.

12.3 AMC 20-24 Compliance

For installations seeking certification to AMC20-24 or other applicable standards, additional compliance information is available on request from Trig Avionics Limited.

13. Installation Drawings

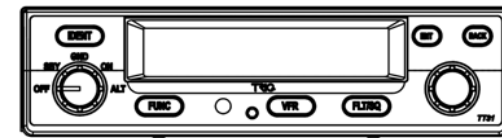
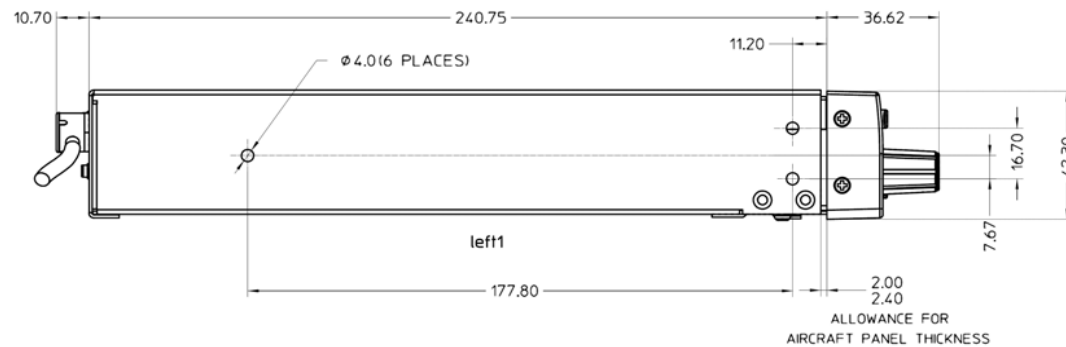
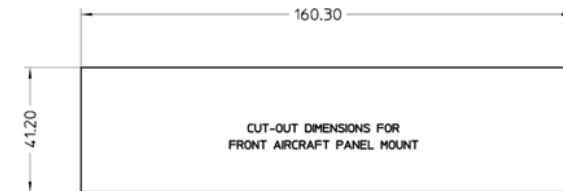
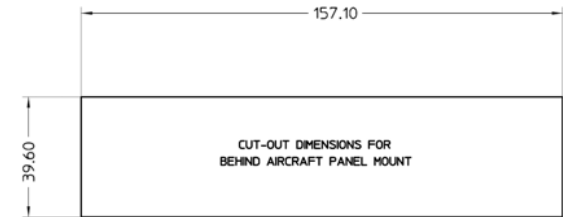
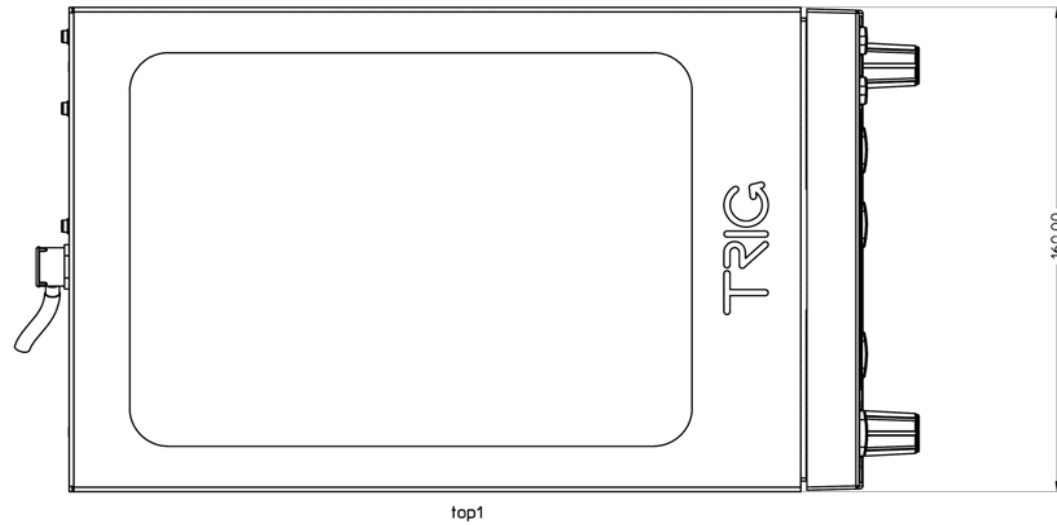

All dimensions in millimetres

14. Basic Interconnect Diagram

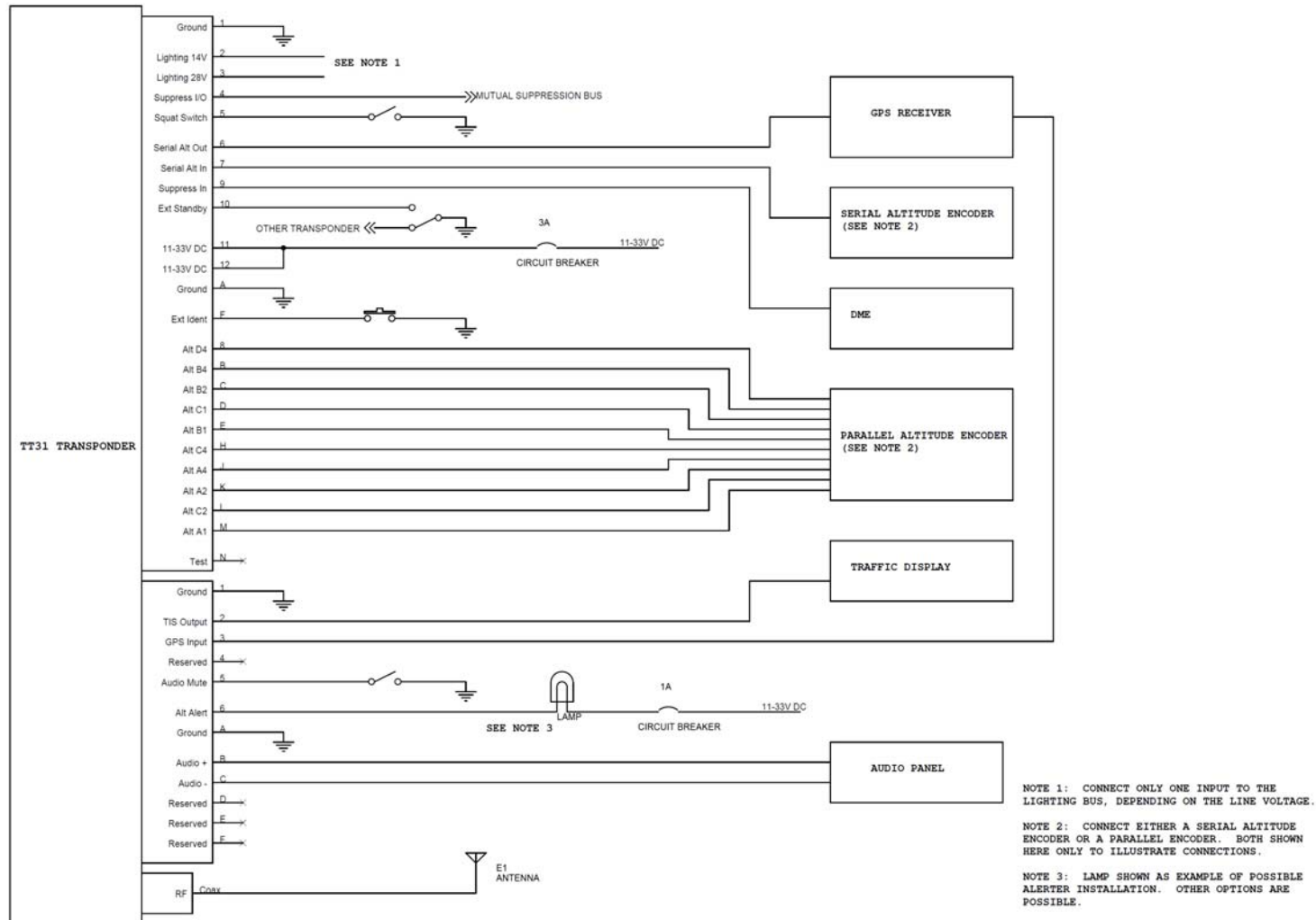

This page intentionally left blank